

1004-0160...0400,1004(TSK) SERIES TILTING ROTARY TABLE

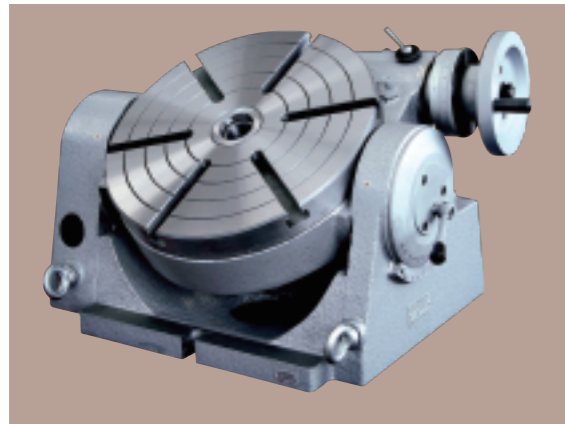

THE 1004(TSK) series tilting rotary table are one of main accessories for milling, boring and drilling machines. They can be used for machining the oblique hole or surface and hole of compound angle at one set-up. Besides this, it is so designed as to be used in a vertical position to carry out center work with a tailstock. This table can be tilted to any position from 0° to 90° and locked. A flange for connecting scroll chuck is special supplied and packed separately. For special order, the dividing plates accessory allows the operator to accurately divide the 360° rotation of the clamping surface into divisions of 2 through 66, and all divisible of 2,3 and 5 from 67-132.

Main specifications

Specifications Items	1004-0160 (TSK160)	1004-0200 (TSK200)	1004-0250 (TSK250)	1004-0320 (TSK320)	1004-0400 (TSK400)
Diameter of table mm	φ 160	φ 200	φ 250	φ 320	φ 400
Diameter of the center hole	2#	3#	3#	4#	4#
Diameter of the center hole mm	φ 25X6	φ 30X6	φ 30X6	φ 40X10	φ 40X10
Width of T-slot mm	10	12	12	14	14
Modules of worm and worm gear	1.5	1.75	2	2.5	3.5
Width of locating key mm	12	14	14	18	18
Adjacent angle of T-slot	90°	90°	60°	60°	60°
Transmission ratio of the worm gear	1: 90	1: 90	1: 90	1: 90	1: 90
Graduation of the table	360°	360°	360°	360°	360°
Tilting angle	0°~90°	0°~90°	0°~90°	0°~90°	0°~90°
Readout of the handwheel	1'	1'	1'	1'	1'
Minimum value of vernier	10"	10"	10"	10"	10"
Minimum reading of the tilting vernier	2'	2'	2'	2'	2'
Indexing accuracy	80"	60"	60"	60"	60"
Max.bearing(with table Hor.)Kg	100	150	200	250	300
Max.bearing(with table Vert.)Kg	50	75	100	125	150
Net weight Kg	36	57	80	135	280
Gross weight Kg	44	67	93	150	305
Case dimensions mm	425X380X300	492X423X306	550X430X330	630X490X395	830X600X460
Matching chuck	K11125	K11160	K11200	K11250	K11325

1004-0160...0400,1004 (TSK) SERIES TILTING ROTARY TABLE

1004-0160...0400,1004(TSK) Dimensional Sketch

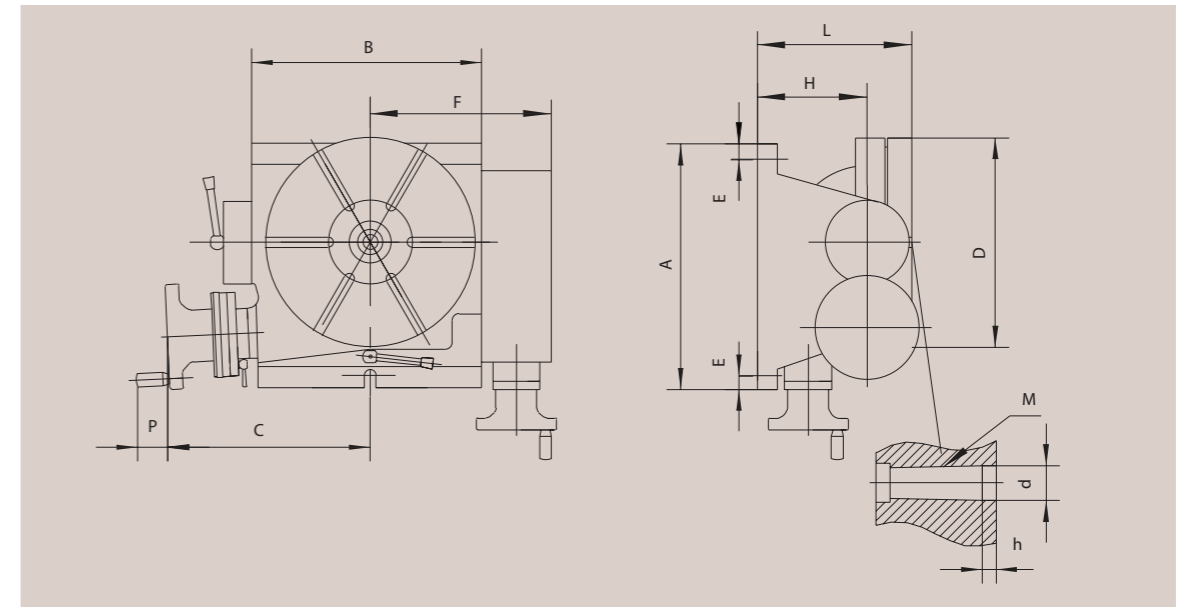

1004-0100...0400,1004(TSK): Installation sketch and dimensions

	1004-0160 (TSK160)	1004-0200 (TSK200)	1004-0250 (TSK250)	1004-0320 (TSK320)	1004-0400 (TSK400)
A	255	296	310	380	500
B	172	213	252	322	400
C	168	186	235	252	306
D	φ 160	φ 200	φ 250	φ 320	φ 400
E	11	14	14	16	16
F	138	175.5	199	241	295
H	100	120	140	175	217
L	160	180	205	255	320
M	MT2	MT2	MT3	MT3	MT4
P	40	40	40	40	50
d	φ 25	φ 30	φ 30	φ 40	φ 40
h	6	6	6	10	10