

1003-0100...0800,1003(TSL) SERIES ROTARY TABLE

THE 1003 (TSL) series horizontal and vertical rotary tables. circular cutting,angle setting,boring,spot facing operations and similar work in conjunction with a milling machine.This type rotary table is designed so as to permit machining operations are at a higher dimension than that of 1001 (TS) type rotary table. The base can be used in a vertical position to enable to carry out center work with the help of tailstock.

A flange for connecting scroll chucks are supplied and packed separately. For special order, the dividing plates accessory allows theoperator to accurately divide the 360° rotation of the clamping surface into divisions of 2 through 66, and all divisible of 2,3 and 5 from 67-132.



Main specifications

Specifications Items	1003-0100 (TSL100)	1003-0160 (TSL160)	1003-0200 (TSL200)	1003-0250 (TSL250)	1003-0320 (TSL320)	1003-0400 (TSL400)	1003-0800 (TSL800)
Diameter of table mm	φ 100	φ 160	φ 200	φ 250	φ 320	φ 400	φ 800
Morse Taper of the center hole	2#	2#	3#	3#	4#	4#	6#
Diameter of the center hole mm	φ 20X8	φ 25X6	φ 30X6	φ 30X6	φ 40X10	φ 40X10	φ 75X14
Height of center for Vert.mounting mm	70	125	150	170	210	260	500
Width of T-slot mm	6	10	12	12	14	14	22
Adjacent angle of T-slot	90°	90°	90°	60°	60°	60°	45°
Width of locating key mm	10	12	14	14	18	18	22
Modules of worm and worm gear	1	1.5	1.75	2	2.5	3.5	5.5
Transmission ratio of the worm gear	1: 72	1: 90	1: 90	1: 90	1: 90	1: 90	1: 120
Graduation of the table	360°	360°	360°	360°	360°	360°	360°
Readout of the handwheel	2'	1'	1'	1'	1'	1'	1'
Minimum value of vernier	10"	10"	10"	10"	10"	10"	10"
Indexing accuracy	120"	80"	60"	60"	60"	60"	60"
Max.bearing(with table Hor.)Kg	20	100	150	200	250	300	1500
Max.bearing(with table Vert.)Kg	10	50	75	100	125	150	750
Net weight Kg	7	23	31.5	46	77	150	--
Gross weight Kg	8	30	42	57	92	175	1200
Case dimensions mm	245X165X112	432X432X220	450X440X235	510X460X240	590X580X250	750X684X286	1247X1222X510
Maching chuck	K1180	K11125	K11160	K11200	K11250	K11325	K11630A

1003-0100...0800,1003(TSL) SERIES ROTARY TABLE

1003-0100...0800,1003(TSL) Dimensional Sketch

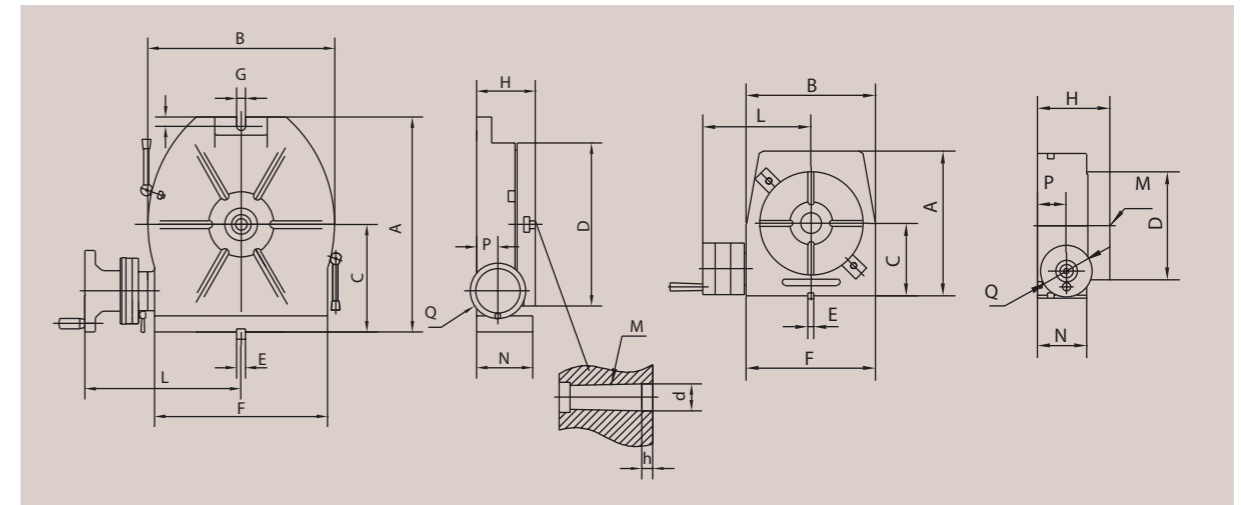

1003-0100...0800,1003(TSL): Installation sketch and dimensions

	1003-0100 (TSL100)	1003-0160 (TSL160)	1003-0200 (TSL200)	1003-0250 (TSL250)	1003-0320 (TSL320)	1003-0400 (TSL400)	1003-0800 (TSL800)
A	125	242	285	328	410	525	980
B	125	196	236	286	360	450	890
C	70	125	150	170	210	260	500
D	φ 100	φ 160	φ 200	φ 250	φ 320	φ 400	φ 800
E	10	12	14	14	18	18	22
F	125	186	208	253	320	400	800
G	/	12	14	14	18	18	22
H	70	85	100	110	120	150	300
J	/	12	15	16	16	16	30
L	114	194	211	241	273	337	534
M	MT2	MT2	MT3	MT3	MT4	MT4	MT6
N	48	82	99	106	118	145	295
P	30	37	48	48	48	70	136
Q	50	125	125	125	140	160	250
d	φ 20	φ 25	φ 30	φ 30	φ 40	φ 40	φ 75
h	8	6	6	10	10	10	14