

1001-0160...2500,1001 (TS) SERIES ROTARY TABLE



THE 1001 (TS) series horizontal rotary tables are for indexing, circular cutting, angle setting, boring, spot facing operations and similar work in conjunction with a milling machine.
A flange for connecting scroll chuck is special supplied, can be packed independently. For special order, the dividing plates accessory allows the operator to accurately divide the 360° rotation of the clamping surface into divisions of 2 through 66, and all divisible of 2, 3 and 5 from 67-132.

Main specifications

Specifications Items	1001-1600(TS1600A)	1001-2000(TS2000A)	1001-2500(TS2500A)
Table diameter mm	φ 1600	φ 2000	φ 2500
Diameter of the through hole	φ 100	φ 120	
Diameter of the center hole mm	φ 120x25	φ 150x30	
Width of T-slot mm	22	22	22
Adjacent angle of T-slot	22.5°	22.5°	22.5°
Modules of worm and worm gear	8	8	8
Transmission ratio of the worm gear	1:120	1: 180	1: 180
Graduation of the table	360°	360°	360°
Rotating angle of table with one revolution of the worm	3°	2°	2°
Minimum value of vernier	10"	10"	10"
Indexing accuracy	30"	30"	30"
Max.workload kg	5500	8500	10000
Net weight Kg		7500	
Gross weight Kg			
Case dimensions mm			

1001-0160...1250,1001 (TS) SERIES ROTARY TABLE

1001-0160...1250,1001 (TS) Dimensional Sketch

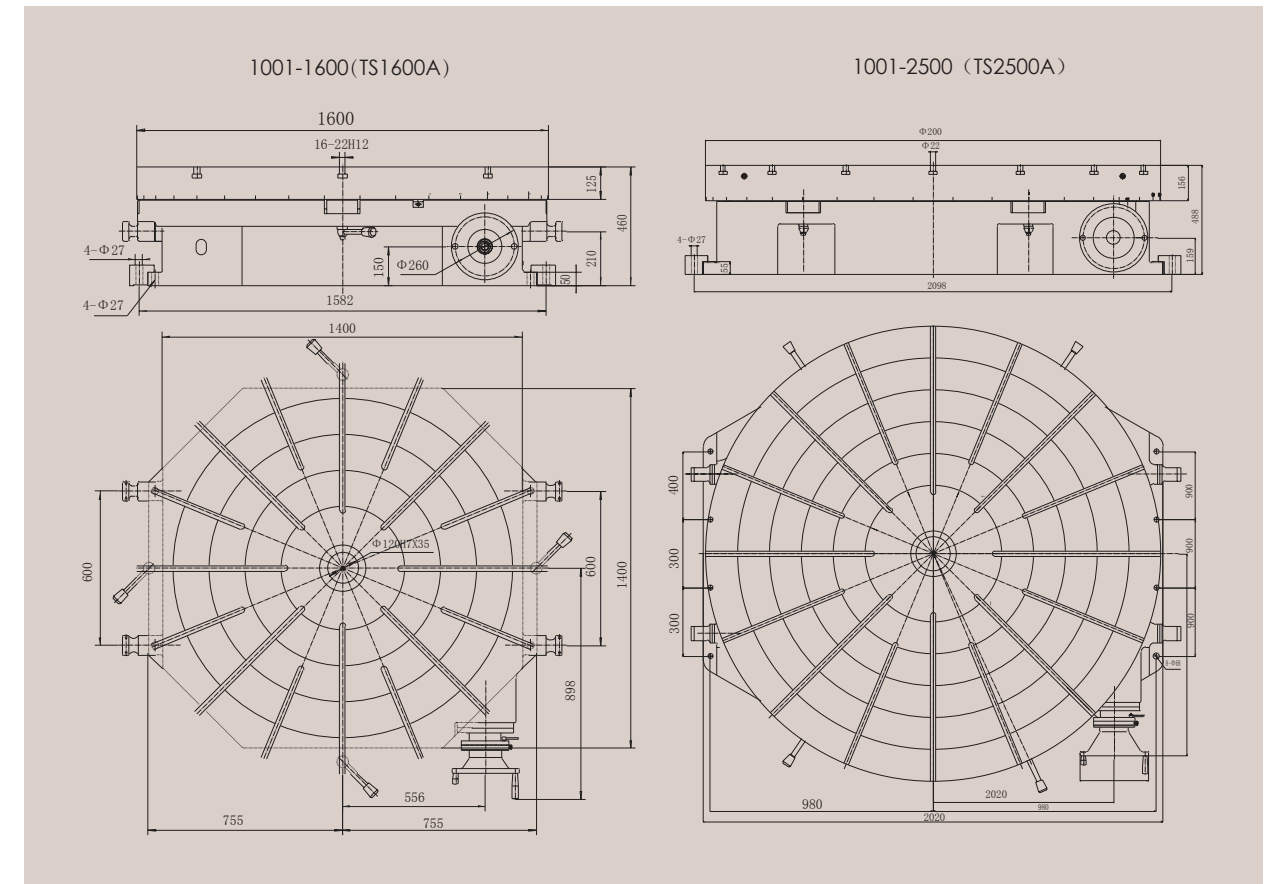

HITECH (Qingdao) ENTERPRISES INC