

1001-0160...2500,1001(TS) SERIES ROTARY TABLE

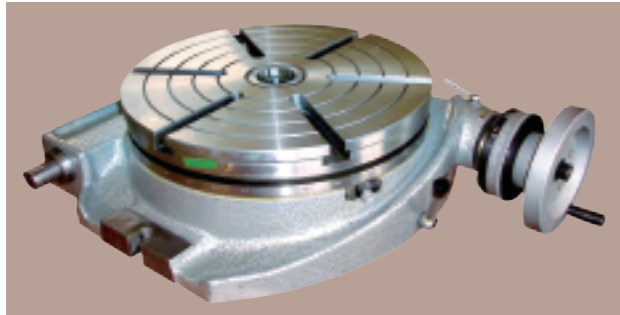

THE 1001(TS) series horizontal rotary tables are for indexing, circular cutting, angle setting, boring, spot facing operations and similar work in conjunction with a milling machine.

A flange for connecting scroll chuck is special supplied and packed separately. For special order, the dividing plates accessory allows the operator to accurately divide the 360° rotation of the clamping surface into divisions of 2 through 66, and all divisible of 2, 3 and 5 from 67-132.

Main specifications

Specifications Items	1001-0160 (TS160A)	1001-0200 (TS200A)	1001-0250 (TS250A)	1001-0320 (TS320A)	1001-0400 (TS400A)	1001-0500 (TS500A)	1001-0630 (TS630A)	1001-0800 (TS800A)	1001-1000 (TS1000A)	1001-1250 (TS1250A)
Table diameter mm	φ 160	φ 200	φ 250	φ 320	φ 400	φ 500	φ 630	φ 800	φ 1000	φ 1250
Diameter of the center hole mm	2#	3#	3#	4#	4#	5#	5#	6#	6#	
Diameter of the center hole mm	φ 25X6	φ 30X6	φ 30X6	φ 40X10	φ 40X10	φ 50X12	φ 50X12	φ 75X14	φ 75X14	φ 75X14
Width of T-slot	10	12	12	14	14	18	18	22	22	22
Adjacent angle of T-slot	90°	90°	60°	60°	60°	45°	45°	45°	45°	45°
Width of locating key mm	12	14	14	18	18					
Modules of worm and worm gear	1.5	1.75	2	2.5	3.5	3.5	4.5	5.5	5.5	5
Transmission ratio of the worm gear	1:90	1:90	1:90	1:90	1:90	1:120	1:120	1:120	1:120	1:180
Graduation of the table	360°	360°	360°	360°	360°	360°	360°	360°	360°	360°
Rotating angle of table with one revolution of the worm	4° (1° per graduation)	4° (1° per graduation)	4° (1° per graduation)	4° (1° per graduation)	4° (1° per graduation)	3° (1° per graduation)	3° (1° per graduation)	3° (1° per graduation)	3° (1° per graduation)	2°
Minimum value of vernier	10"	10"	10"	10"	10"	10"	10"	10"	10"	10"
Indexing accuracy	80"	60"	60"	60"	60"	60"	60"	30"	30"	30"
Max. workload kg	100	150	200	250	300	550	700	1250	2000	3000
Net weight Kg	16.5	22.5	33.5	65	125	215	345	800	1300	1900
Gross weight Kg	21.5	31	44.5	76	145	238	377	855	1400	2000
Case dimensions mm	400X330X200	440X360X208	500X400X210	580X480X238	750X616X238	850X730X302	995X900X326	1175X1090X391	1430X1224X550	1585X1580X503
Maching chuck	K11125	K11160	K11200	K11250	K11325	K11400	K11500	K11630A	K11630A	K11500A

1001-0160...2500,1001(TS) SERIES ROTARY TABLE

1001-0160...2500,1001(TS) Dimensional Sketch

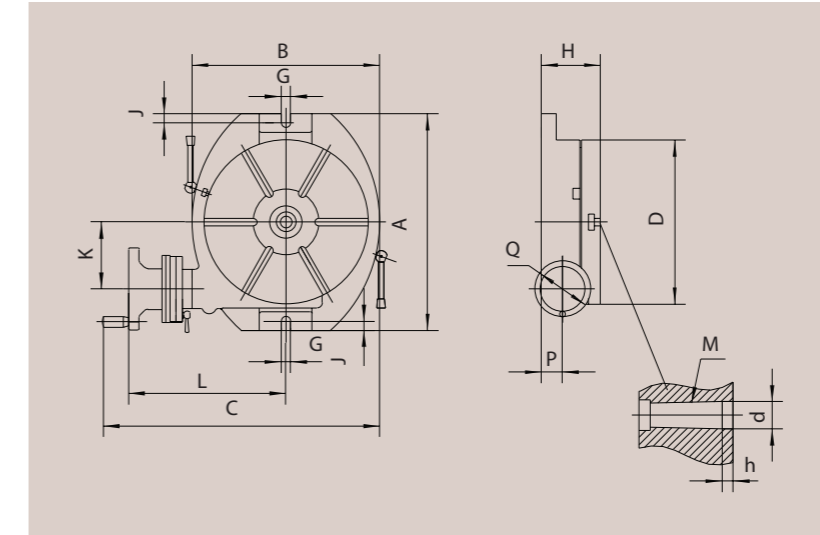

1001-0160...2500,1001(TS): Installation sketch and dimensions

	1001-0160 (TS160A)	1001-0200 (TS200A)	1001-0250 (TS250A)	1001-0320 (TS320A)	1001-0400 (TS400A)	1001-0500 (TS500A)	1001-0630 (TS630A)	1001-0800 (TS800A)	1001-1000 (TS1000A)	1001-1250 (TS1250A)
A	260	290	330	410	530	640	820	1000	1170	1400
B	196	236	286	360	450	560	700	890	1080	1300
C	332	369	422	493	612	753	898	1080	1295	1420
D	φ 160	φ 200	φ 250	φ 320	φ 400	φ 500	φ 630	φ 800	φ 1000	φ 1250
G	12	14	14	18	18	22	22	22	-	22
H	75	80	90	110	140	158.5	160	215	250	283
J	12	14	14	18	18	22	22	30	-	30
K	76	91.25	102.5	128.5	180	230	295	364	364	487.5
L	194	211	241	273	337	393	468	535	654	690
M	MT2	MT3	MT3	MT4	MT4	MT5	MT5	MT6	MT6	-
P	27	27	30.5	44	60	65	68	76	106	116
Q	125	125	125	125	160	180	220	250	250	250
d	φ 25	φ 30	φ 30	φ 40	φ 40	φ 50	φ 50	φ 75	φ 75	φ 75
h	6	6	6	10	10	12	12	14	14	14

Accessories T-slot bolt set 2 sets